



MINISTRY OF EDUCATION, SINGAPORE
 in collaboration with
 CAMBRIDGE INTERNATIONAL EDUCATION
 General Certificate of Education Advanced Level

CANDIDATE
 NAME

--

CENTRE
 NUMBER

S				
---	--	--	--	--

INDEX
 NUMBER

--	--	--	--

* 0 1 2 3 4 5 6 7 8 9 *

PHYSICS

8867/02

Paper 2 Structured Questions

For examination from 2026

SPECIMEN PAPER

2 hours

You must answer on the question paper.

No additional materials are needed.

INSTRUCTIONS

- Section A: answer **all** questions.
- Section B: answer **one** question.
- Use a black or dark blue pen. You may use an HB pencil for any diagrams or graphs.
- Write your name, centre number and candidate number in the boxes at the top of the page.
- Write your answer to each question in the space provided.
- Do **not** use an erasable pen. Do **not** use correction fluid or tape.
- Do **not** write on any bar codes.
- You may use an approved calculator.

INFORMATION

- The total mark for this paper is 80.
- The number of marks for each question or part question is shown in brackets [].

This document has **22** pages. Any blank pages are indicated.



Singapore Examinations and Assessment Board



CAMBRIDGE
 International Education

Data

speed of light in free space	$c = 3.00 \times 10^8 \text{ m s}^{-1}$
elementary charge	$e = 1.60 \times 10^{-19} \text{ C}$
unified atomic mass constant	$u = 1.66 \times 10^{-27} \text{ kg}$
rest mass of electron	$m_e = 9.11 \times 10^{-31} \text{ kg}$
rest mass of proton	$m_p = 1.67 \times 10^{-27} \text{ kg}$
the Avogadro constant	$N_A = 6.02 \times 10^{23} \text{ mol}^{-1}$
gravitational constant	$G = 6.67 \times 10^{-11} \text{ N m}^2 \text{ kg}^{-2}$
acceleration of free fall	$g = 9.81 \text{ m s}^{-2}$

Formulae

uniformly accelerated motion	$s = ut + \frac{1}{2}at^2$
	$v^2 = u^2 + 2as$
electric current	$I = Anvq$
resistors in series	$R = R_1 + R_2 + \dots$
resistors in parallel	$1/R = 1/R_1 + 1/R_2 + \dots$

Section A

Answer **all** the questions in this section.

- 1 (a) State the principle of conservation of momentum.

.....
 [2]

- (b) A tennis ball of mass 56 g is moving horizontally towards a tennis racket with a speed of 42 m s^{-1} . A player hits the ball back in the opposite direction with a speed of 54 m s^{-1} .

- (i) Calculate the change in the momentum of the ball.

change in momentum = kg m s^{-1} [2]

- (ii) Determine the impulse provided by the racket. State the unit.

impulse = [1]

- (iii) State and explain whether momentum is conserved in this collision.

.....
 [1]

[Total: 6]

2 (a) Potential energy can be stored in different physical systems.

For each of the following, state the equation for potential energy and give an example of a situation where it is increasing.

(i) gravitational potential energy

.....
 [2]

(ii) elastic potential energy

.....
 [2]

(b) Figure 2.1 shows a man during a bungee jump. Several stages of the jump are shown and labelled.

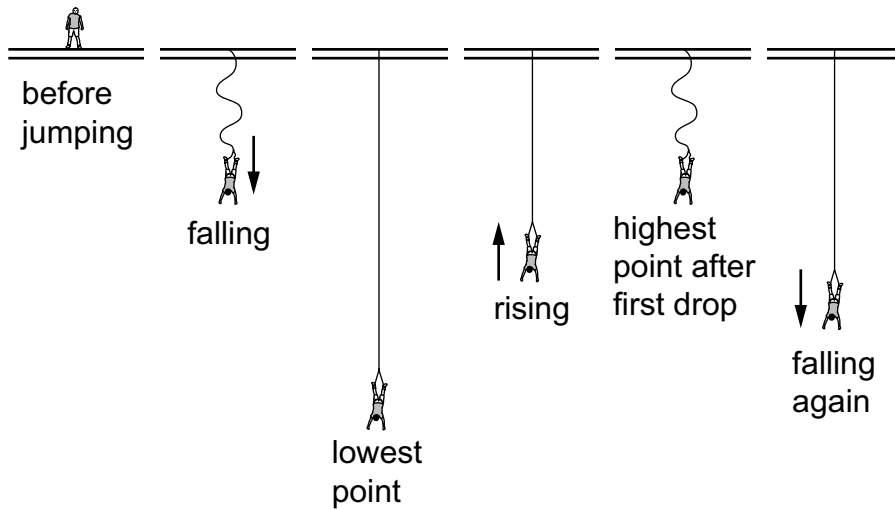

Figure 2.1

The man has a mass of 82 kg and free-falls over a distance of 50 m for approximately 3 s before the elastic rope attached to him starts to stretch. During the free fall, the man experiences some air resistance.

(i) Show that the kinetic energy of the man at the lowest point of the free fall is approximately 40 000 J.

[2]

- (ii) The man comes to a rest after three bounces.

Sketch a graph, using the axes below, to show how the kinetic energy of the man changes with time during the bungee jump.

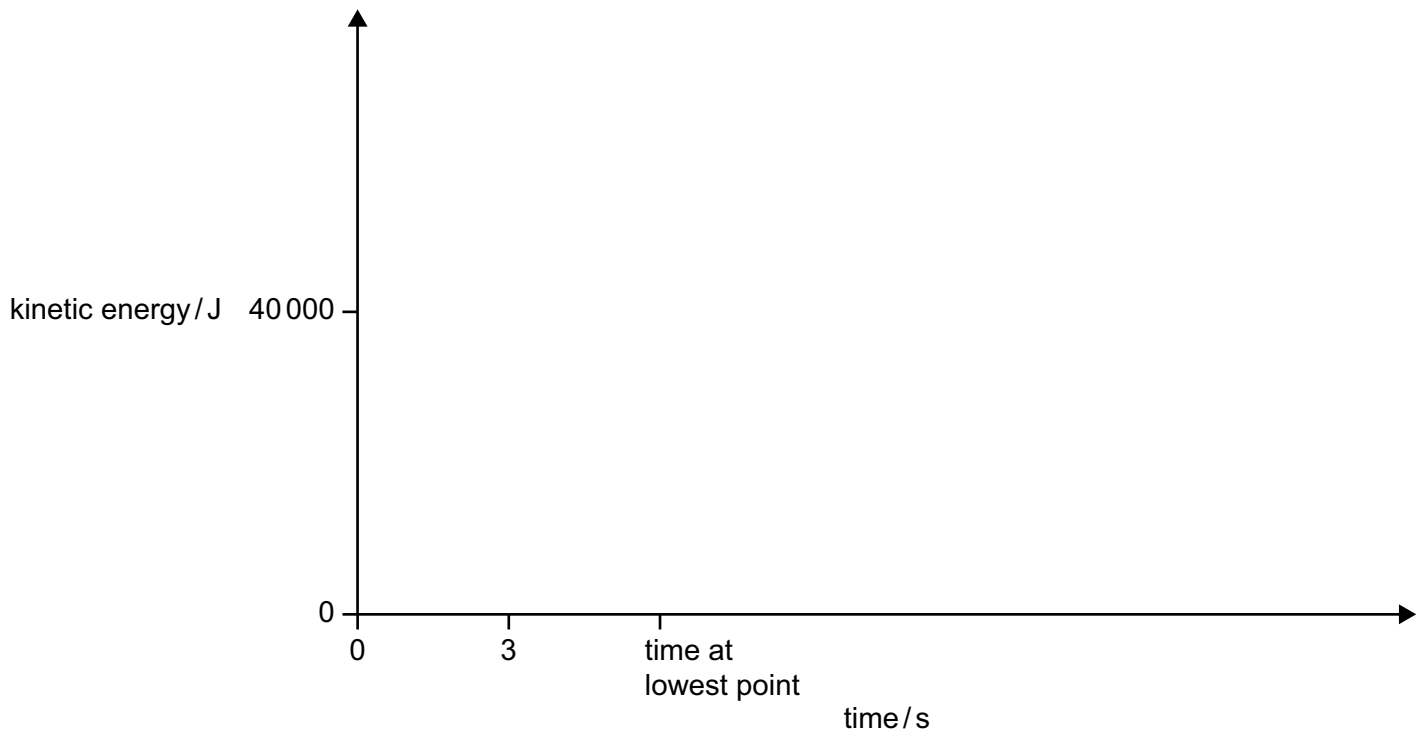

[4]

[Total: 10]

- 3 In a cathode-ray oscilloscope (c.r.o), electrons are accelerated in a vacuum from a heated filament towards a disc with a hole at its centre.

(a) The potential difference between the filament and the disc is +200 V.

Assuming that the initial speed of the electrons is negligible, show that their speed when they reach the disc is $8.38 \times 10^6 \text{ m s}^{-1}$.

[2]

- (b) The electrons pass through the hole in the disc and into a uniform electric field between two parallel plates, as shown in Figure 3.1.

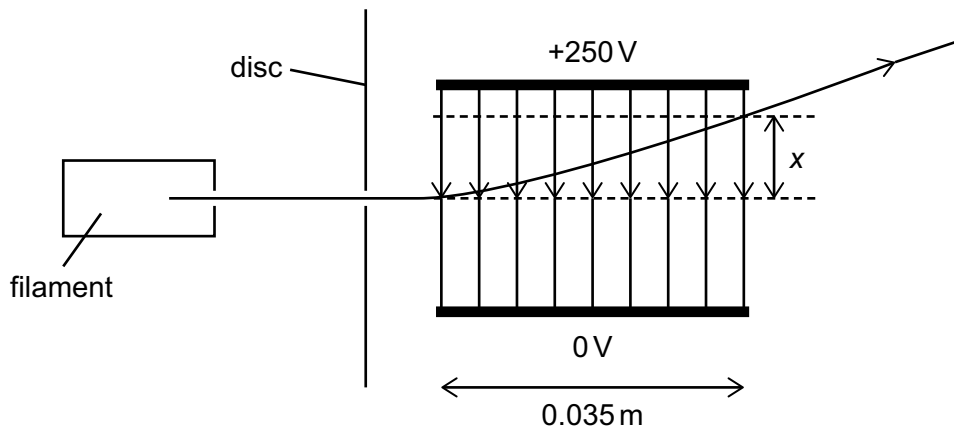

Figure 3.1

The two parallel plates are of length 0.035 m. The bottom plate is earthed (at a potential of 0 V) and the top plate is at a potential of +250 V.

The electric field between the plates has strength $12.5 \times 10^3 \text{ N C}^{-1}$.

- (i) Calculate the acceleration of electrons towards the top plate when **between** the plates.

acceleration m s^{-2} [2]

- (ii) Calculate the vertical distance x moved by the electrons, as shown on Figure 3.1, in the time they are between the plates.

$x = \dots\dots\dots$ m [3]

- (c) A magnetic field initially produces a deflection of the electrons in the same direction as that produced by this electric field.

Determine the direction of this magnetic field.

.....
..... [1]

[Total: 8]

4 (a) (i) Describe, with the aid of a diagram, the Rutherford α -particle scattering experiment.

.....
.....
.....
.....
..... [3]

(ii) Explain what can be inferred from the results of the experiment.

.....
.....
..... [2]

- (b) To determine the half-life of a radioactive substance, a scientist carried out an experiment using a ratemeter.

The ratemeter readings were obtained over a period of 16 days. The readings obtained are plotted on the graph shown in Figure 4.1.

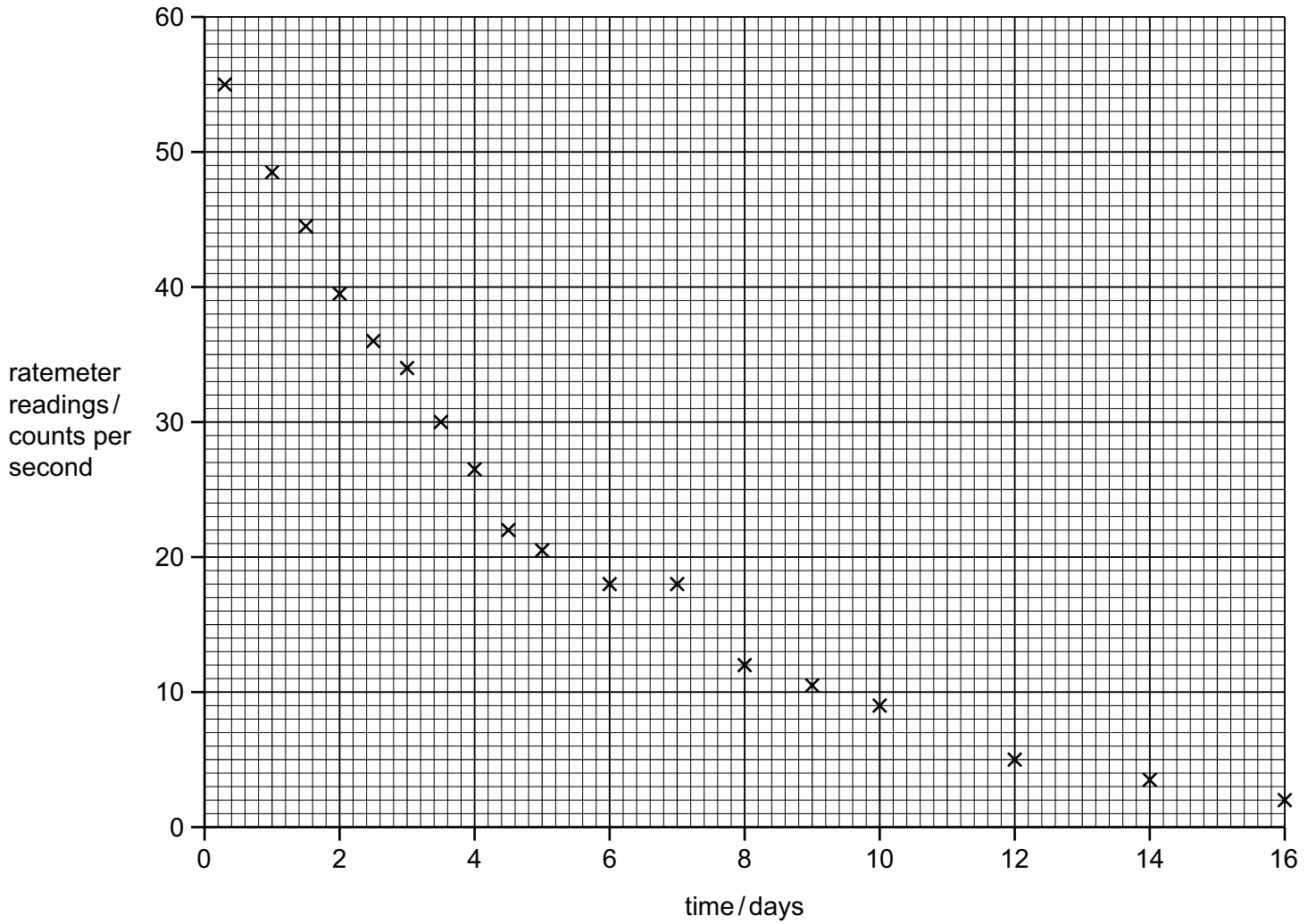

Figure 4.1

- (i) Draw the best-fit smooth curve on the graph. [2]
- (ii) Determine the half-life of the radioactive substance. Show your working on the graph.

half-life = days [2]

[Total: 9]

- 5 A negative temperature coefficient (NTC) thermistor is connected in series with a $1.0\text{ k}\Omega$ fixed resistor and a 1.5 V cell with negligible internal resistance.

The diameter of the semiconductor material in the thermistor is 4.37 mm .

- (a) (i) At a temperature of $20\text{ }^\circ\text{C}$, the number density of charge carriers in the semiconductor is $3.5 \times 10^{18}\text{ m}^{-3}$. The current in the cell is 0.16 mA .

Calculate the drift velocity of the charge carriers in the semiconductor.

drift velocity = m s^{-1} [3]

- (ii) Explain how the drift velocity in the metal wires is different from the drift velocity calculated in 5(a)(i).

.....
.....
..... [2]

- (iii) Suggest why it is expected that almost no charge carriers in the semiconductor will actually be moving at the speed calculated in 5(a)(i).

.....
..... [1]

- (b) The temperature of the thermistor rises.

Explain the change that this causes to the potential difference across the thermistor in terms of the number density of charge carriers.

.....
.....
.....
..... [3]

[Total 9]

Turn over

- 6 While participating in a Tour de France cycle race, a cyclist needs to eat between three and five times the average normal daily energy requirement. This question asks you to consider why.

In one Tour de France race, records show that on one day a cyclist rode a distance of 161 km in a time of 4 hours, 48 minutes and 20 seconds.

- (a) Calculate his average speed on this day.

average speed = m s^{-1} [2]

- (b) During one 15 km section of the race on this day, the cyclist climbed approximately 1300 m.

For this cyclist, the time taken since the start of the section was measured at 7 different places over the 15 km section.

The graphs on page 13, showing the cyclist's performance, are plotted with straight lines between the points representing the measurements.

- (i) Figure 6.1 shows the altitude above sea level at the places where times were measured.

Figure 6.2 shows the time taken to reach each of the 7 places where measurements are taken.

Explain why these two graphs have a similar shape.

.....

 [2]

- (ii) Sketch on Figure 6.3 a graph to show the variation in the average speed of the cyclist between the places where measurements were taken on the 15 km section. [5]

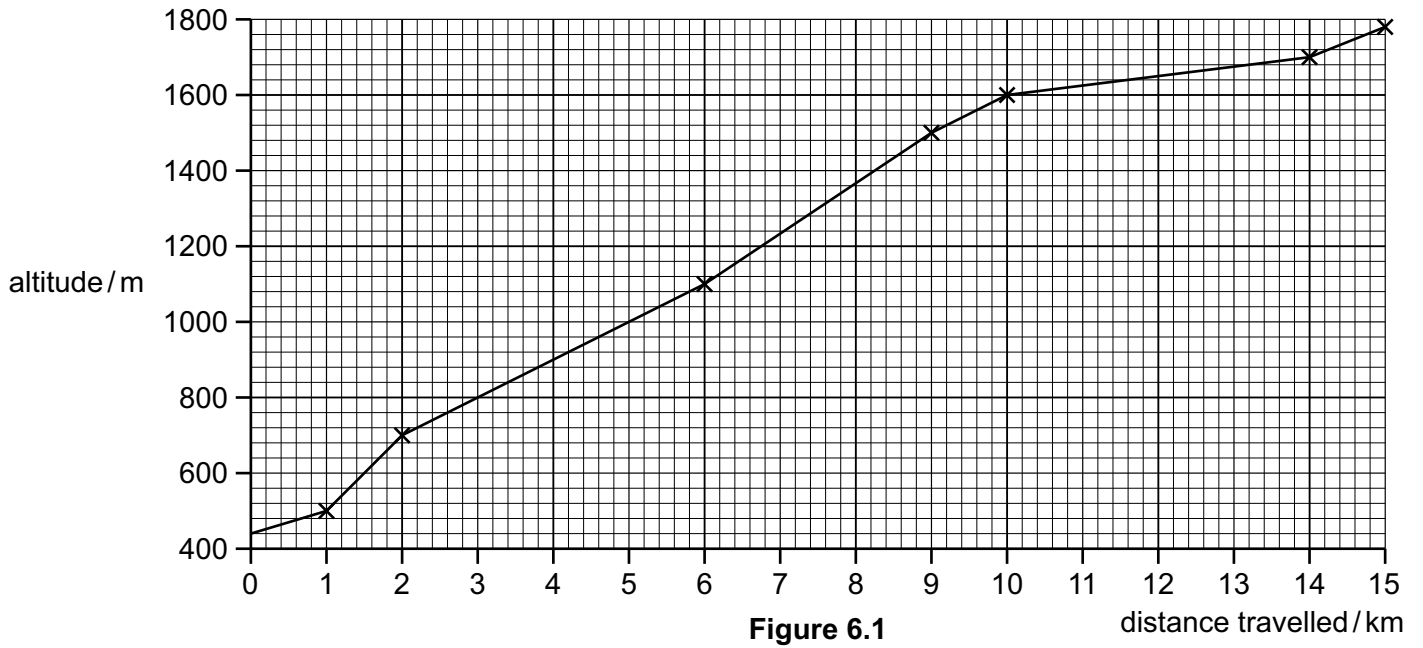

Figure 6.1

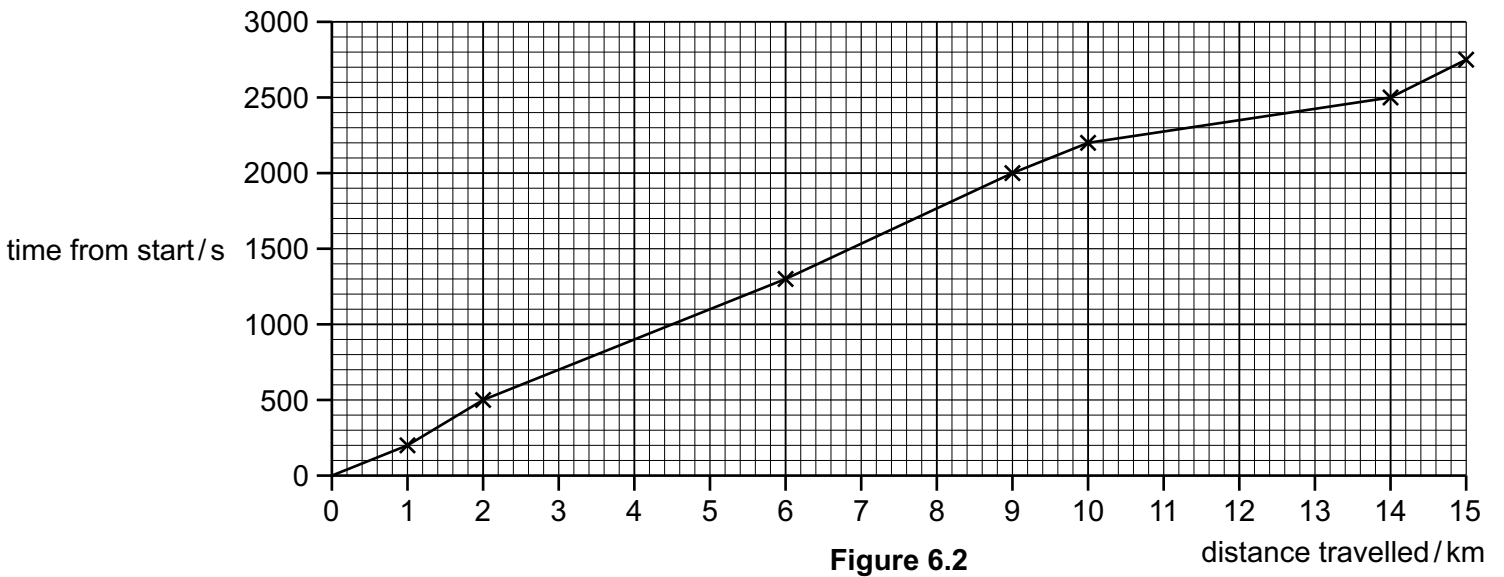

Figure 6.2

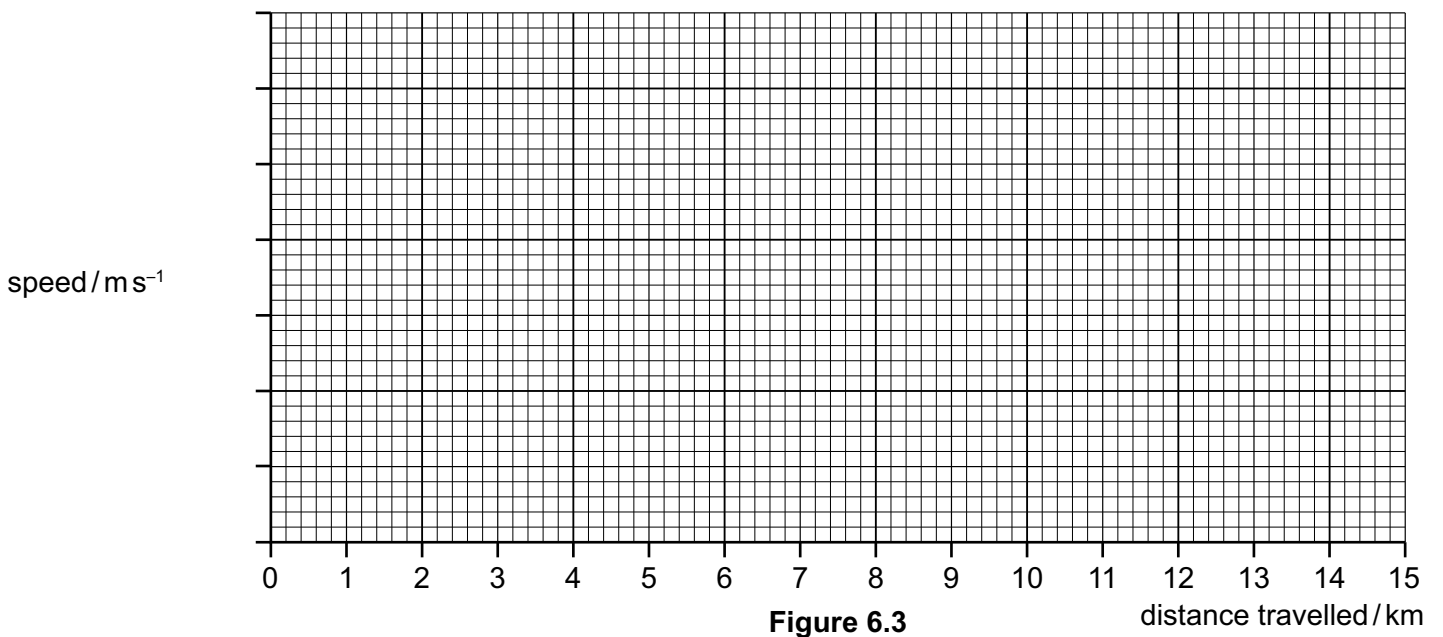

Figure 6.3

- (c) In order to find the power output of a competitor in the Tour de France, an estimate needs to be made of the work done against air resistance and friction.

Assume that, during the stage from the 6th km mark to the 9th km mark, the total resistive force has a value of 24 N. The cyclist and bike have a total mass (body mass) of 78 kg.

Calculate, for these 3 km:

- (i) the work done by the cyclist against the resistive forces

work done = J [1]

- (ii) the power per unit body mass, supplied by the cyclist, in doing work against the resistive forces

power per unit body mass = W kg^{-1} [3]

- (iii) the **total power** per unit body mass, supplied by the cyclist over these 3 km.

total power per unit body mass = W kg^{-1} [3]

(d) A typical office worker, of average mass 70 kg, needs around 12 000 kJ every 24 hours to maintain his mass.

(i) Calculate the total power per unit body mass for the office worker.

total power per unit body mass = W kg^{-1} [1]

(ii) Compare your answer in **6(d)(i)** with the energy needed by a cyclist in the Tour de France and comment on the difference.

.....
.....
..... [1]

[Total: 18]

Section B

Answer **one** question in this section.

7 (a) State Newton's three laws of motion.

first law

.....

second law

.....

third law

.....

[3]

(b) Figure 7.1 is a diagram of a ball rotating in a horizontal circular path on the end of a piece of light inextensible string which is fixed at one end.

(i) Complete Figure 7.1 to show the forces acting on the ball.
Classify each force as either a gravitational or a contact force.

Assume air resistance is negligible.

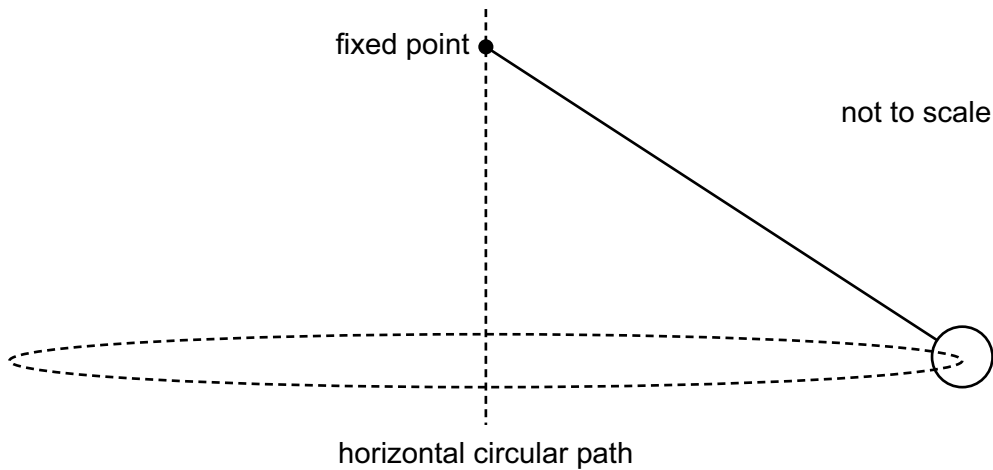

Figure 7.1

[2]

(ii) Identify and describe the reaction force pair to each of the forces you have drawn.

.....

.....

..... [2]

- (iii) The string is of length 0.70 m and makes an angle of 50° with the vertical.
The mass of the ball is 40 g.

Calculate the speed of the ball.

$$\text{speed} = \dots\dots\dots \text{ m s}^{-1} \text{ [3]}$$

- (iv) Calculate the tension in the string.

$$\text{tension} = \dots\dots\dots \text{ N [1]}$$

- (c) The Moon has a mass of 7.35×10^{22} kg. Its mean distance from the centre of the Earth is 3.84×10^8 m. It makes a complete, almost circular, orbit of the Earth in 27.3 days.

In the following calculations, ignore any effect due to the fact that both the Earth and the Moon are rotating around the Sun.

Calculate the following quantities:

- (i) the time, in seconds, for the Moon to make a single orbit of the Earth

$$\text{time} = \dots\dots\dots \text{ s [1]}$$

- (ii) the speed of the Moon in its orbit

$$\text{speed} = \dots\dots\dots \text{ m s}^{-1} \text{ [1]}$$

- (iii) the angular velocity of the Moon around the Earth

$$\text{angular velocity} = \dots\dots\dots \text{ rad s}^{-1} \text{ [2]}$$

(iv) the centripetal acceleration of the Moon

centripetal acceleration = m s^{-2} [2]

(v) the gravitational force the Earth exerts on the Moon

force = N [1]

(vi) the mass of the Earth.

mass = kg [2]

[Total: 20]

- 8 The unlabeled lines on the graph in Figure 8.1 show how the current through an ohmic resistor, a semiconductor diode and a filament lamp vary with the applied potential difference.

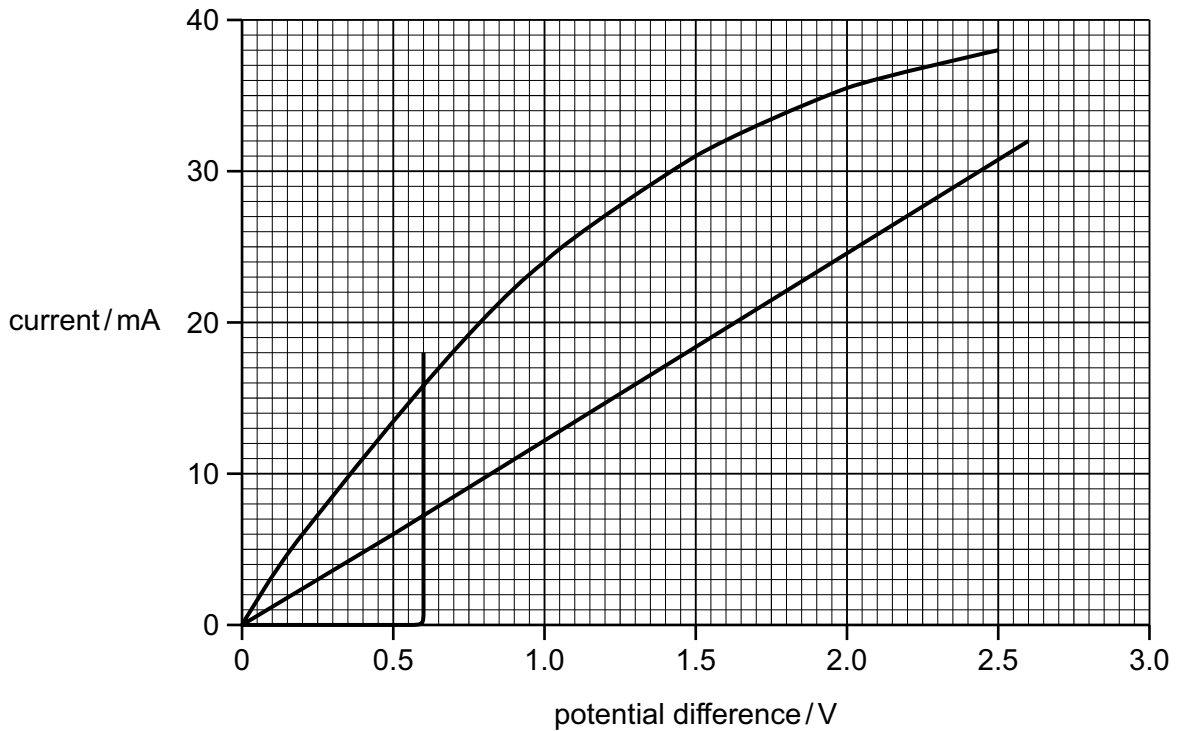

Figure 8.1

- (a) Use Figure 8.1 to find the following values when the applied potential difference is 0.5 V:

- (i) the resistance of the ohmic resistor

resistance = Ω [2]

- (ii) the power supplied to the ohmic resistor

power = W [2]

- (iii) the resistance of the filament lamp

resistance = Ω [2]

- (b) Explain the shape of the graph for the filament lamp.

.....
 [2]

- (c) If a potential difference of 12 V is applied across the semiconductor diode, it will be destroyed. A protective resistor is placed in series with it to limit the current to 18 mA.

This is shown in Figure 8.2.

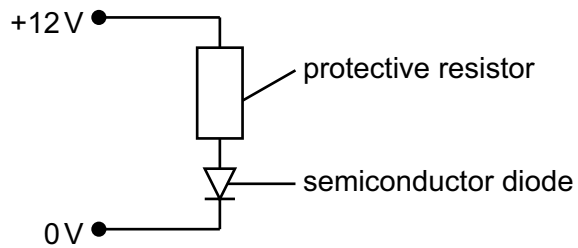

Figure 8.2

Calculate the value of the protective resistor required.

resistance = Ω [2]

- (d) An NTC thermistor circuit is used to switch on a cooling system when the temperature increases to a pre-set value.

Draw a suitable circuit diagram for such a system. Your control circuit needs to control the mains circuit but must not be connected to the mains circuit.

[3]

- (e) The electrical circuit shown in Figure 8.3 is unusual because the presence of resistor R makes it impossible to apply the usual rules for either series or parallel connections.

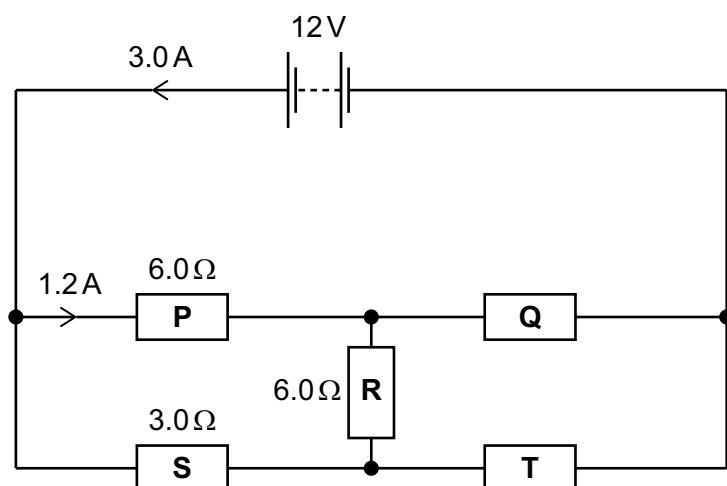

Figure 8.3

The battery has no internal resistance.

Complete the following table for each of the components shown in Figure 8.3. Show your working clearly in the spaces provided.

component	current / A	potential difference / V	resistance / Ω
battery	from battery = 3.0	emf = 12	zero
resistor P	1.2		6.0
resistor Q			
resistor R			6.0
resistor S			3.0
resistor T			

[7]

[Total: 20]

BLANK PAGE

Permission to reproduce items where third-party owned material protected by copyright is included has been sought and cleared where possible. Every reasonable effort has been made by the publisher (Cambridge University Press & Assessment) to trace copyright holders, but if any items requiring clearance have unwittingly been included, the publisher will be pleased to make amends at the earliest possible opportunity.

Cambridge International Education is the name of our awarding body and a part of Cambridge University Press & Assessment, which is a department of the University of Cambridge.